

71-4159-250
5/09



Billboard artwork may vary.

Lionel Animated Billboard Owner's Manual

Congratulations!

Congratulations on your purchase of the Lionel Animated Billboard! This accessory alternates between two classic advertisements.

Table of contents

Wiring your Animated Billboard	3
Wiring the accessory with the separate switch	4
Installing your Animated Billboard	5
Operating your Animated Billboard	5
Installing your Animated Billboard with TrainMaster Command Control	6-7
Lionel Limited Warranty Policy & Service	8

The following Lionel marks may be used throughout this instruction manual and are protected under law. All rights reserved.

Lionel®, *TrainMaster®*, *Odyssey®*, *RailSounds®*, *CrewTalk™*, *TowerCom™*, *DynaChuff™*, *StationSounds™*, *Pullmor®*, *ElectroCoupler™*, *Magne-Traction®*, *CAB-I® Remote Controller*, *PowerMaster®*, *Lionel ZW®, ZW®*, *PowerHouse®*, *TMCC®*, *Lionelville™*, *Lockon®*, *Wireless Tether™*, *LionMaster®*, *FatBoy™*, *American Flyer®*, *TrainSounds™*, *PowerMax™*, *LEGACY™*, *PowerMax™ Plus*, *Odyssey II™*, *LEGACY RailSounds™*

The name FasTrack® is used with permission from Pitsco, Inc.

Wiring your Animated Billboard

Power your Animated Billboard with a separate accessory power supply, through the track with a Lionel Lockon (available separately, 6-62900), or a FasTrack Accessory Power Wire (available separately, 6-12053). Refer to figure 1 as you connect the accessory.

Caution! To make the proper connections, the ends of the wires must be stripped back 1/4" to 3/8". Use a pair of wire strippers or a sharp knife to strip the wires. Only an adult should perform this task! Always use care when stripping wires.

1. Separate the two wires at the back of the Billboard.
2. Connect one of the Billboard wires directly to a terminal on the power supply, Lionel Lockon, or FasTrack Accessory Power Wire. When using the FasTrack Accessory Power Wire, twist one of the Billboard wires to one of the FasTrack Accessory Power Wires. We recommend using a wire nut (not included) to insulate the connection.

Lockon users: To make the wire connections, press down on the top of the terminal clip so that a metal loop is formed. Slide the bare end of the wire into the exposed loop. Release pressure on the terminal clip, allowing the crimped metal to pinch the end of the wire in the metal loop. Give a little tug on the wire to check if the hold is secure.

3. Connect the other Billboard wire to the remaining power supply terminal, Lockon terminal, or the FasTrack Accessory Power Wire. When using the FasTrack Accessory Power Wire, twist the remaining Billboard wire to the remaining FasTrack Accessory Power Wire. We recommend using a wire nut (not included) to insulate the connection.

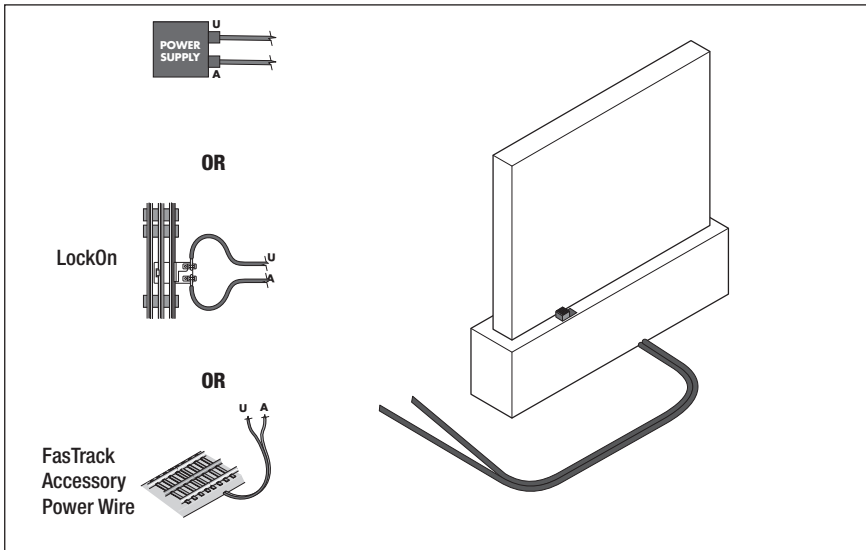

Figure 1. Conventional power connections

Wiring the accessory with the separate switch

If you are placing this accessory at a location on your layout that is difficult to reach, we recommend that you connect the separate switch that is included with this accessory. Simply connect one of the Billboard wires to a switch terminal and connect the other switch terminal to a power supply terminal using an extra wire. Connect the remaining accessory wire directly to the other power supply terminal. Refer to Figure 2. Be sure that the switch on the back of the Billboard is in the ON position.

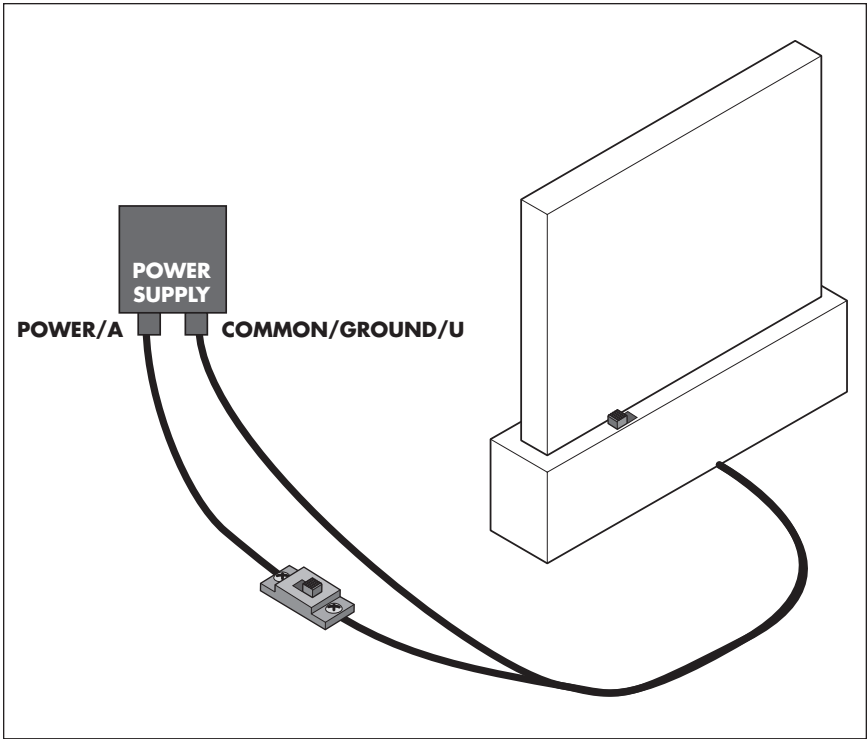

Figure 2. Power and switch connections

Installing your Animated Billboard

Choose a visible location on your layout so you can show off your Animated Billboard! You may use the two tabs at the base of the accessory to secure your Billboard to your layout with two screws (not included).

Operating your Animated Billboard

Switch the signs with the press of a button.

- 1. Power up your Billboard.**
- 2. Locate the switch at the back of the Billboard and slide it to the ON position. If you have connected the separate switch, slide the switch to the ON position as well.**
- 3. Use your transformer to adjust the voltage. We recommend 13-18 volts (AC).** If the power is set too high, the sign will change forcefully, jarring the Billboard from side to side. If the power is set too low, the sign will not change completely.

With the switch in the ON position and the accessory powered up, the Billboard will automatically alternate between the two advertisements at regular intervals.

Installing your Animated Billboard with TrainMaster Command Control

For operation in the TrainMaster Command Control environment, you may choose to wire your Billboard with an SC-2 Switch and Accessory Controller (available separately, 6-22980) or the Accessory Switch Controller (available separately, 6-14182). Refer to these manuals for additional information.

SC-2 wiring and operation

Three wires are needed to connect your Animated Billboard to the SC-2 and a separate accessory transformer. Refer to Figure 3.

1. Attach one wire to the Common/Ground/U terminal of the transformer and connect it to the accessory COMM (common) position on the SC-2.
2. Attach one of the Billboard wires to the accessory toggle ON/OFF position on the SC-2.
3. Finally, connect the remaining Billboard wire to the Power/A terminal on the transformer.

Use the AUX1 button on your CAB-1 Remote Controller to switch the advertisements on display.

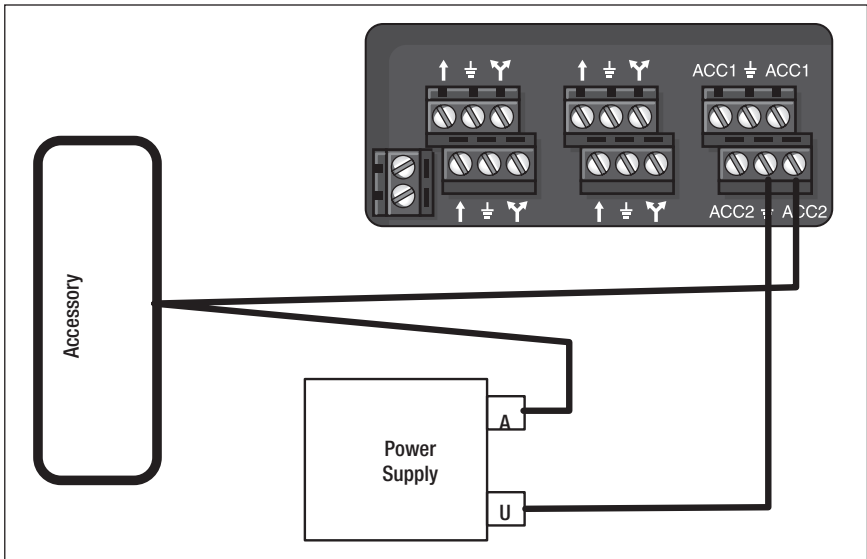

Figure 3. SC-2 connections

Installing your Animated Billboard with TrainMaster Command Control (continued)

Accessory Switch Controller wiring and operation

Three wires are needed to connect your Animated Billboard to the Accessory Switch Controller (ASC) and a separate accessory transformer. Refer to Figure 4.

1. **Attach one wire to the Power/A terminal of the transformer and connect it to the COMM terminal on the ASC.**
2. **Attach one of the Billboard wires to a numbered accessory terminal on the ASC.**
3. **Finally, connect the remaining Billboard wire to the Common/Ground/U terminal on the transformer.**

Use the AUX2 button on your CAB-1 Remote Controller to switch the advertisements on display.

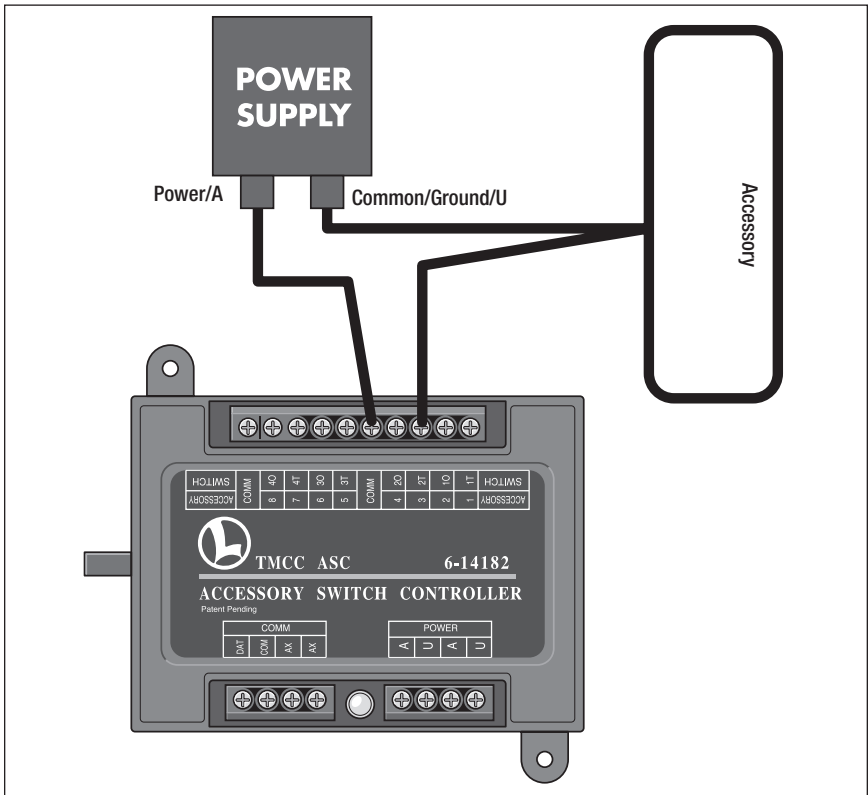

Figure 4. ASC connections

Lionel Limited Warranty Policy & Service

This Lionel product, including all mechanical and electrical components, moving parts, motors and structural components, with the exception of LIGHT BULBS & LED's are warranted to the original owner-purchaser for a period of **one year from the original date of purchase** against original defects in materials or workmanship when purchased through a **Lionel Authorized Retailer***.

This warranty does **NOT** cover the following: Normal wear and tear, Light bulbs or LED's, Defects appearing in the course of commercial use, or Damage resulting from abuse/misuse of the product.

Transfer of this product by the original owner-purchaser to another person voids this warranty in its entirety. Modification of this product in any way; visually mechanically or electronically, voids the warranty in its entirety.

Any warranted product which is defective in original materials or workmanship and is delivered by the *original owner-purchaser* (this warranty is non-transferrable) to Lionel LLC or any Lionel Authorized Service Station **MUST** be accompanied by the original receipt for purchase (or copy) from an **Lionel Authorized Retailer***, will at the discretion of Lionel LLC, be repaired or replaced, without charge for parts or labor. In the event the defective product cannot be repaired, and a suitable replacement is not available, Lionel will offer to replace the product with a comparable model (**determined by Lionel LLC**), if available. In the event a comparable model is not available the customer will be refunded the original purchase price (requires proof of purchase from the **Lionel Authorized Retailer*** it was originally purchased). Any products on which warranty service is sought must be sent freight or postage prepaid (Lionel will refuse any package when postage is due). **Transportation and shipping charges are not covered as part of this warranty.**

NOTE: Products that require service that do not have a receipt from an LIONEL AUTHORIZED RETAILER* will be required to pay for all parts required to repair the product (labor will not incur a charge) providing the product is not older than 5 years from date of manufacture and is within 1 year from date of purchase. A copy of the original sales receipt is required.

In no event shall Lionel LLC be held liable for incidental or consequential damages.

Some states do not allow the exclusion or limitation of incidental or consequential damages, so the above exclusion may not apply to you.

This warranty gives you specific legal rights and you may have other rights which vary from state to state.

Instructions for Obtaining Service

If service for this Lionel LLC product is required; bring the item, along with your DATED sales receipt and completed warranty information (at the bottom of this page) to the nearest Lionel Authorized Service Station. Your nearest Lionel Service Station can be found by calling 1-800-4-LIONEL or by accessing the website at www.lionel.com.

If you prefer to send your Lionel product directly to Lionel, for repair you must **FIRST** call 586-949-4100 extension 9105 or FAX Lionel at 586-949-5429 or write to Customer Service, 50625 Richard W. Blvd, Chesterfield, MI 48051-2493. Please have the 6-digit Lionel product number, the date of original purchase, the dealer where the item was purchased and what seems to be the problem. You will receive a Verbal return authorization (RA) number to ensure your merchandise will be properly tracked and handled upon receipt at Lionel LLC.

Once you have your Return Authorization (RA) number, make sure the item is packed in its original Styrofoam inner container which is placed inside the original outer display box (this will help prevent damage during shipping and handling). This shipment **MUST** be prepaid and we recommend that it be insured with the carrier of your choice.

Please make sure you have followed all of the above instructions carefully before returning any merchandise for service. You may choose to have your product repaired by one of Lionel LLC's Authorized Service Stations after its warranty has expired. A reasonable service fee should be expected once the product warranty has expired.

Warranty Information

Please complete the information below and keep it, along with your **DATED ORIGINAL SALES RECEIPT**. You **MUST** present this form **AND** your **DATED SALES RECEIPT** when requesting warranty service.

*A complete listing of Lionel Authorized retailers can be found by calling 1-800-4-LIONEL or by visiting our website at www.lionel.com.

Products that are more than 5 years old, from date of manufacture, are not applicable for warranty coverage, even if they have never been sold prior to this date. (Under no circumstance shall any components or labor be provided free of charge.)

Name _____

Address _____

Place of Purchase _____

Date of Purchase _____

Product Number _____

Product Description _____

